

Anemometer WAA151

USER'S GUIDE

M210293en-A
April 2002



PUBLISHED BY

Vaisala Oyj
P.O. Box 26
FIN-00421 Helsinki
Finland

Phone (int.):+358 9 8949 1
Fax: +358 9 8949 2227

Visit our Internet pages at <http://www.vaisala.com/>

© Vaisala 2002

No part of this manual may be reproduced in any form or by any means, electronic or mechanical (including photocopying), nor may its contents be communicated to a third party without prior written permission of the copyright holder.

The contents are subject to change without prior notice.

Please observe that this manual does not create any legally binding obligations for Vaisala towards the customer or end user. All legally binding commitments and agreements are included exclusively in the applicable supply contract or Conditions of Sale.

Table of Contents

CHAPTER 1	
GENERAL INFORMATION	3
About This Manual	3
Contents of This Manual	3
Version Information	4
Related Manuals	4
Safety	4
General Safety Considerations	4
Product Related Safety Precautions	5
ESD Protection	5
Regulatory Compliances	6
Warranty	6
CHAPTER 2	
PRODUCT OVERVIEW	7
Introduction to WAA151 Anemometer	7
CHAPTER 3	
INSTALLATION	9
Selecting Location	9
Installation Procedure	10
Mounting	10
Alignment	12
Verification	12
Connector	12
CHAPTER 4	
MAINTENANCE	15
Periodic Maintenance	15
Cleaning	15
Testing Proper Operation	15
Replacing Consumables	16
Parts List for Consumables	20

CHAPTER 5

TROUBLESHOOTING..... 21

Common Problems 21

Getting Help 22

Return Instructions 23

CHAPTER 6

TECHNICAL DATA..... 25

Specifications 25

MTBF 26

MTTR 26

List of Figures

Figure 1 WAA151 Anemometer..... 8

Figure 2 Recommended Mast Location in Open Area..... 9

Figure 3 Recommended Mast Length on the Top of
Building 10

Figure 4 Mounting of Wind Sensor 11

Figure 5 WAA151 Connector..... 12

Figure 6 WAA151 Assembly..... 19

List of Tables

Table 1 Manual Revisions 4

Table 2 Related Manuals 4

Table 3 Available Spare Parts..... 20

Table 4 Some Common Problems and their Remedies 21

Table 5 WAA151 Anemometer Specifications..... 25

Table 6 MTBF Values..... 26

CHAPTER 1

GENERAL INFORMATION

About This Manual

This manual provides information for installing, operating, and maintaining the WAA151 Anemometer.

Contents of This Manual

This manual consists of the following chapters:

- Chapter 1, General Information, provides important safety and revision history information for the product.
- Chapter 2, Product Overview, introduces the WAA151 Anemometer features.
- Chapter 3, Installation, provides you with information that is intended to help you install this product.
- Chapter 4, Maintenance, provides information that is needed in the basic maintenance of the WAA151 Anemometer.
- Chapter 5, Troubleshooting, describes common problems, their probable causes and remedies, and contact information.
- Chapter 6, Technical Data, provides the technical data of the WAA151 Anemometer.

Version Information

Table 1 Manual Revisions

Manual Code	Description
M210293en-A	This manual, the first version of the WAA151 Anemometer User's Guide.

Related Manuals

Table 2 Related Manuals

Manual Code	Manual Name
M210294en	WAV151 Wind Vane - User's Guide

Safety

General Safety Considerations

Throughout the manual, important safety considerations are highlighted as follows:

WARNING	Warning alerts you to a serious hazard. If you do not read and follow instructions very carefully at this point, there is a risk of injury or even death.
----------------	---

CAUTION	Caution warns you of a potential hazard. If you do not read and follow instructions carefully at this point, the product could be damaged or important data could be lost.
----------------	--

NOTE	Note highlights important information on using the product.
-------------	---

Product Related Safety Precautions

The WAA151 Anemometer delivered to you has been tested for safety and approved as shipped from the factory. Note the following precautions:

WARNING	Ground the product, and verify outdoor installation grounding periodically to minimize shock hazard.
----------------	--

CAUTION	Do not modify the unit. Improper modification can damage the product or lead to malfunction.
----------------	--

ESD Protection

Electrostatic Discharge (ESD) can cause immediate or latent damage to electronic circuits. Vaisala products are adequately protected against ESD for their intended use. However, it is possible to damage the product by delivering electrostatic discharges when touching, removing, or inserting any objects inside the equipment housing.

To make sure you are not delivering high static voltages yourself:

- Handle ESD sensitive components on a properly grounded and protected ESD workbench. When this is not possible, ground yourself to the equipment chassis before touching the boards. Ground yourself with a wrist strap and a resistive connection cord. When neither of the above is possible, touch a conductive part of the equipment chassis with your other hand before touching the boards.

- Always hold the boards by the edges and avoid touching the component contacts.

Regulatory Compliances

The WAA151 complies with the following performance and environmental test standards:

- Wind tunnel tests per ASTM standard method D5096-96 (for starting threshold, distance constant, transfer function; refer to Chapter 6, Technical Data on page 25)
- Exploratory vibration test per MIL-STD-167-1
- Humidity test per MIL-STD-810E, Method 507.3
- Salt fog test per MIL-STD-810E, Method 509.3

Warranty

For certain products Vaisala normally gives a limited one year warranty. Please observe that any such warranty may not be valid in case of damage due to normal wear and tear, exceptional operating conditions, negligent handling or installation, or unauthorized modifications. Please see the applicable supply contract or conditions of sale for details of the warranty for each product.

CHAPTER 2

PRODUCT OVERVIEW

This chapter introduces the WAA151 Anemometer features.

Introduction to WAA151 Anemometer

The WAA151 is an optoelectronic, fast-response, low-threshold anemometer. In the cup wheel it has three light-weight conical cups providing excellent linearity over the entire operating range, up to 75 m/s. Rotated by the wind, a chopper disc attached to the cup wheel's shaft cuts an infrared light beam 14 times per revolution, generating a pulse train output from a phototransistor.

The output pulse rate can be regarded directly proportional to wind speed, for example, 246 Hz = 24.6 m/s. For best available accuracy, however, the characteristic transfer function should be used, see section Specifications on page 25, to compensate for starting inertia and slight overspeeding.

The heating element in the shaft tunnel keeps the temperature of the bearings above the freezing level in cold climates. Nominally it provides 10 W of heating power. It is recommended to use a thermostat switch in the sensor cross arm for switching the heating power on below +4 °C.

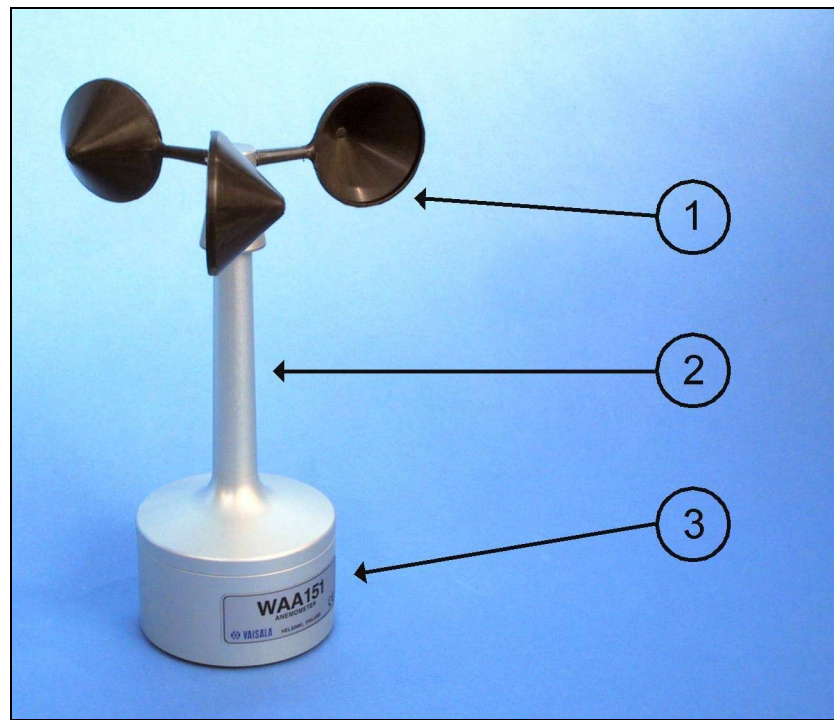

0204-039

Figure 1 WAA151 Anemometer

The following numbers refer to Figure 1 above:

- 1 = Cup wheel assembly
- 2 = Sensor shaft
- 3 = Lower body

CHAPTER 3

INSTALLATION

This chapter provides you with information that is intended to help you install this product.

Selecting Location

Allow sufficient clearance for the wind sensors. Wind sensors should not be located next to a building or any other object that might affect the flow of air.

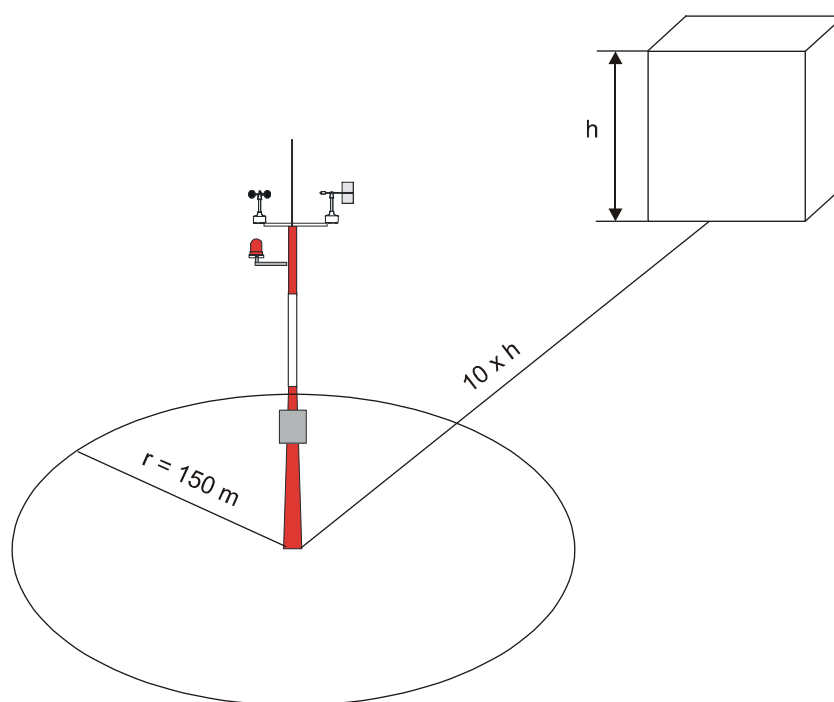

0204-040

Figure 2 Recommended Mast Location in Open Area

In general, any object of height (h) will not remarkably disturb wind measurement at a minimum distance of $10 \times h$. There should be at least 150 m open area in all directions from the mast. Minimum distance between the mast and obstacles is ten times the height of an obstacle. Refer to Figure 2 on page 9.

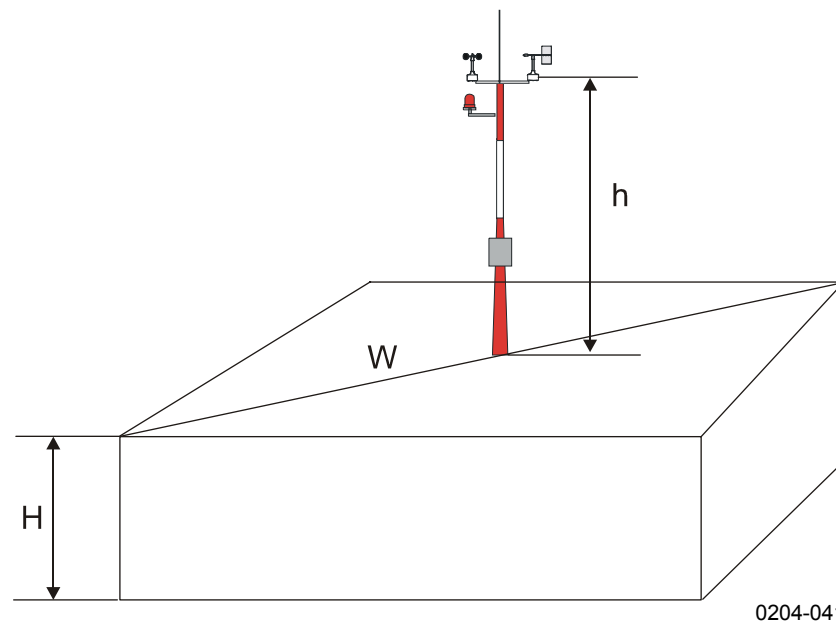

Figure 3 Recommended Mast Length on the Top of Building

The recommended minimum length (marked with the letter h in Figure 3 above) for the mast that is installed on the top of a building is 1.5 times the height of the building (H). When the diagonal (W) is less than the height (H) the minimum length of the mast is $1.5 \times W$.

Installation Procedure

Mounting

Sensor installation is most convenient when you use a Vaisala manufactured cross arm for mounting the sensor.

Always mount the WAA151 Anemometer to the southern end of the cross arm.

1. It is recommended that you remove the cup assembly to ease installation.
2. Fit the 6-pin cable plug through the mounting flange at the end of the cross arm, then connect it to the sensor. See Figure 4 below.
3. The sensor fits to the cross arm in one position only. Face the product label south and mount the sensor to the flange by twisting. Note that the plastic washers (1) should be inserted between the flange and the sensor. See Figure 4 below.
4. Finally, tighten the screws (2) with an Allen key (3). See Figure 4 below.
5. Mount the cup assembly and tighten its fixing screw.

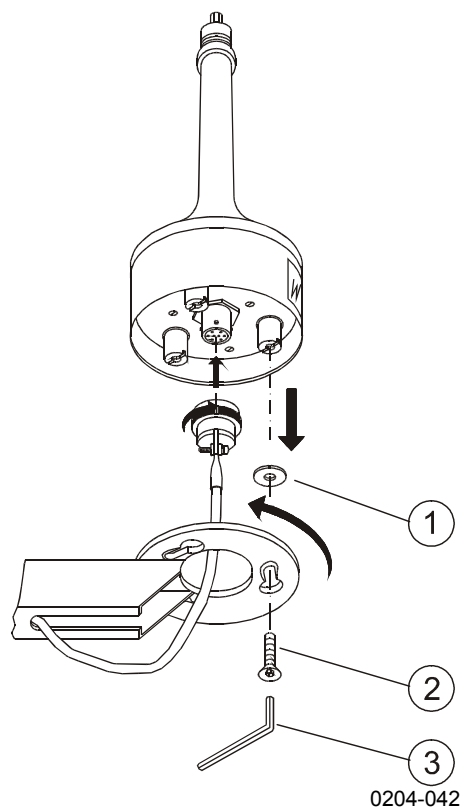

Figure 4 Mounting of Wind Sensor

Alignment

The anemometer does not need any alignment after mounting.

Verification

If your sensor is connected to the data collection system and powered up, check that the speed readings are changing when you rotate the cup wheel manually.

Connector

The connector for the WAA151 is shown in Figure 5 below.

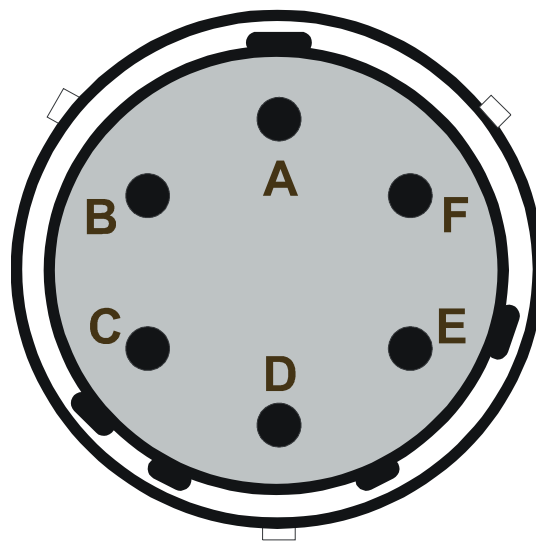

0002-027

Figure 5 WAA151 Connector

The following letters refer to Figure 5 above.

- A = F+, power input from 9.5 to 15.5 VDC
- B = GND, common ground
- C = Fout, signal output
- D = HTNG, 20 VDC or VAC
- E = HTNG, 20 VDC or VAC
- F = Not connected

The heating element in the shaft tunnel is connected between pins D and E. You can supply the heating element with 20 VDC or VAC.

The recommended cable connector for the sensor is SOURIAU MS3116F10-6P.

This page intentionally left blank.

CHAPTER 4

MAINTENANCE

This chapter provides information that is needed in the basic maintenance of the WAA151 Anemometer.

Periodic Maintenance

Cleaning

Heavy contamination in the cups, such as bird droplets or ice will deteriorate the accuracy of the anemometer. Clean the cups when necessary.

Testing Proper Operation

The sensor will hold its accuracy in all conditions for 1 year. If the rains are mostly casual and moderate, and the atmospheric corrosion is typical, the sensor accuracy will remain for 2 years.

However, the ball bearings must be checked once a year and the sensor shaft rotated manually. To do this, remove the cup wheel. To ensure proper operation, the shaft should spin smoothly and it should not create any detectable noises.

Replacing Consumables

Replacement of the bearings should only be done by a trained technician. To replace the ball bearings, follow the procedure below and refer to Figure 6 on page 19.

1. Open the cup wheel fixing screw with a 2-mm Allen key. Remove the cup wheel assembly.

CAUTION

The cup wheel fixing screw has been treated with sealant. Do not remove the fixing screw to ensure perfect sealing after reassembling.

2. Loosen the hex nut of the connector (use a 22-mm tool).

CAUTION

Be careful not to bend the connector pins.

3. Loosen the three pan head screws at the bottom of the sensor body (use a 7-mm tool).
4. Remove the lower body assembly by pulling it straight outwards.
5. Loosen the spacer screws with a 7-mm tool and disconnect the heating element outlet.
6. Remove the printed circuit board including the opto-coupler.

CAUTION

Do not twist or bend the connector. This may break the pins.

7. Loosen the fixing screw of the chopper disc with a 2-mm Allen key and remove the chopper disc.
8. Remove the external retaining ring (using narrow-pointed pliers).
9. Remove the spacer ring.

10. Remove the internal retaining ring at the bottom of the shaft (using narrow-pointed pliers).
11. Remove the lower bearing.
12. Push out the shaft downwards through the upper body.
13. Remove the top bearing after pulling out the shaft.

To reassemble the sensor, reverse the above work order .
The numbers in parenthesis refer to Figure 6 on page 19.

1. Take the previous steps in opposite order until assembling the chopper disc.

NOTE

Be careful when handling the new ball bearings. Do not drop them or force them onto the shaft.

2. Attach the chopper disc (7) back onto the shaft. The disc has to be positioned so that the disc teeth do not touch the opto-coupler (6) on the circuit board. Tighten the screw.

CAUTION

Assure that the chopper disc teeth do not touch the opto-coupler. There should be 1 to 2 mm space between the bottom of the opto-coupler and the disc teeth.

3. Attach the heating element outlet (5) to the circuit board. Put the circuit board in place and fasten it with spacers (5).
4. Put the lower body assembly (4) carefully into place. Fasten the three screws (3) at the bottom of the sensor. Make sure that the bigger O-ring (14) is correctly positioned between the upper and the lower sensor bodies. The O-ring is recommended to be replaced with a new one after each opening. Check also that the connector's O-ring (14) is properly in its place.

NOTE

When placing the lower body assembly, make sure that the O-ring is correctly positioned between the upper and lower bodies. It is recommended to replace the O-rings with a new ones before reassembling.

5. Tighten the hexagon nut of the connector (2).
6. Connect the cable plug to the sensor body connector. Fasten the sensor body on the crossarm with three screws.
7. Mount the cup assembly onto the sensor body. Tighten the fixing screw.

CAUTION

The heating resistance element cannot be removed without special tools. To avoid any damages, it is recommended that replacement of the heating element be carried out by the manufacturer.

The following numbers refer to Figure 6 on page 19:

- 1 = Cup wheel assembly
- 2 = Hex nut of the connector
- 3 = M6x16 DIN7991 (3 pcs)
- 4 = Lower body
- 5 = Spacer (3 pcs)
- 6 = Printed circuit board (PCB)
- 7 = Chopper disc
- 8 = External retaining ring, body
- 9 = Spacer ring
- 10 = Internal retaining ring, shaft
- 11 = Ball bearings
- 12 = Shaft and Upper body assembly
- 13 = Ball bearings
- 14 = O-rings, 2 pcs

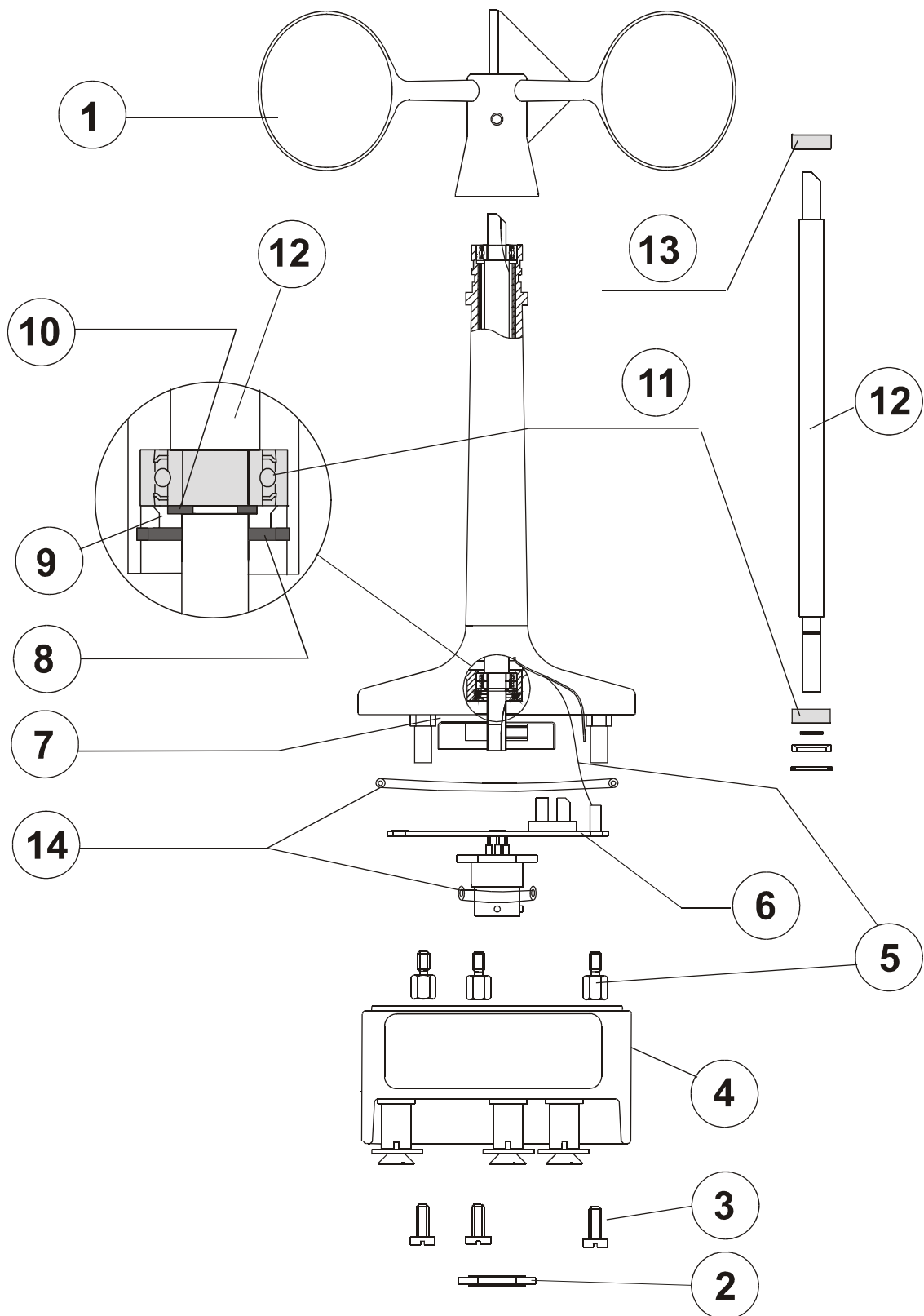

0204-043

Figure 6 WAA151 Assembly

Parts List for Consumables

Table 3 Available Spare Parts

Spare Part	Order Code
Cup assembly	7150WA
Set of bearings and gasket	16644WA
Sensor board (PCB)	1433WA

CHAPTER 5

TROUBLESHOOTING

This chapter describes common problems, their probable causes and remedies, and contact information.

Common Problems

Table 4 Some Common Problems and their Remedies

Problem	Probable Cause	Remedy
The data is not received from the sensor.	The sensor is mechanically damaged.	Check the cables and connectors.
	After removing the connector's hexagon nut, the connector is bent, which breaks the connection wires.	Check the connector.
	The sensor is not powered properly.	Check that the supply voltage is from 9.5 to 15.5 VDC
	Some Vaisala products, for example, WAT12, switch power on to the sensor only for a very short period (200 μ s to 500 μ s).	Check that the sensor output rises above ($U_{IH} - 1.5$ V) at the end of the power pulse.

Problem	Probable Cause	Remedy
The sensor shaft is covered with ice and snow.	The heating element does not function.	Send the sensor to Vaisala for repair. See section Return Instructions on page 23 for details.
	The heating element is not properly connected.	Open the sensor and check that the heating element outlet is connected to the connector on the printed circuit board. Refer to the instructions given in section Replacing Consumables on page 16 for details.
The output from connector pin C tracked with an oscilloscope is not square wave.	The printed circuit board is damaged.	Replace the printed circuit board. Refer to the instructions given in section Replacing Consumables on page 16. See Table 3 on page 20 for spare part number.
The frequency is not equal to 14 times revolution rate.		
Current consumption is more than 28 mA when the shaft is rotated mechanically.		

Getting Help

For technical questions or for comments on the manuals, contact the Vaisala technical support:

E-mail helpdesk@vaisala.com

Telephone +358 9 8949 2789

Fax +358 9 8949 2790

Return Instructions

If the product needs repair, please follow the instructions below to speed up the process and avoid extra costs.

1. Read the warranty information.
2. Write a Problem Report with the name and contact information of a technically competent person who can provide further information on the problem.
3. On the Problem Report, please explain:
 - What failed (what worked / did not work)?
 - Where did it fail (location and environment)?
 - When did it fail (date, immediately / after a while / periodically / randomly)?
 - How many failed (only one defect / other same or similar defects / several failures in one unit)?
 - What was connected to the product and to which connectors?
 - Input power source type, voltage and list of other items (lighting, heaters, motors etc.) that were connected to the same power output.
 - What was done when the failure was noticed?
4. Include a detailed return address with your preferred shipping method on the Problem Report.
5. Pack the faulty product using an ESD protection bag of good quality with proper cushioning material in a strong box of adequate size. Please include the Problem Report in the same box.
6. Send the box to:
Vaisala Oyj
SSD Service
Vanha Nurmijärventie 21
FIN-01670 Vantaa
Finland

This page intentionally left blank.

CHAPTER 6

TECHNICAL DATA

This chapter provides the technical data of the WAA151 Anemometer.

Specifications

Table 5 WAA151 Anemometer Specifications

Property	Description/Value
Sensor/Transducer type	Cup anemometer/Opto-chopper
Measuring range	0.4 ... 75 m/s
Starting threshold	< 0.5 m/s ¹⁾
Distance constant	2.0 m
Transducer output 0 ... 75 m/s Characteristic Transfer Function	0 ... 750 Hz square wave $U_f = 0.1007 \times R + 0.3278$ (U_f = wind speed; R = o/p pulse rate)
Accuracy (within 0.4 ... 60 m/s) With Characteristic Transfer Function With "simple transfer function" $U_f = 0.1 \times R$	± 0.17 m/s ²⁾ ± 0.5 m/s
Transducer output level ($I_{out} < +5$ mA) ($I_{out} > -5$ mA)	High state > $U_{in} - 1.5$ V Low state < 2.0 V
Settling time after power turn-on	< 30 μ s
Operating power supply	9.5 ... 15.5 VDC, 20 mA typical
Heating power supply	20 VDC or VAC, 500 mA typical
Electrical connections	MIL-C-26482 type; 6-wire cable

Property	Description/Value
Recommended connector at cable end	SOURIAU MS3116F10-6P
Operating temperature	-50 ... +55 °C (with shaft heating)
Storage temperature	-60 ... +70 °C
Housing material	AlMgSi, gray anodized
Cup material	PA, reinforced with carbon fiber
Dimensions	240 (h) × 90 (Ø) mm Swept radius of cup wheel: 91 mm
Weight	570 g

- 1) Measured with cup wheel in position least favored by flow direction.
Optimum position yields < 0.35 m/s starting threshold.
- 2) Standard Deviation

MTBF

According to the standard MIL-HDBK-217F calculated mean times between failures are listed in Table 6 below. Actually, the last column provides the failure frequency during 10^6 hours of use.

Table 6 MTBF Values

Abbreviation	Installation	f/10 ⁶ h
Gf	Permanent installations	2.34
Gm	Mobile installations	8.52
Nu	Ship equipments	5.48

MTTR

Mean time to repair is 0.3 h.